

Material Auto Weighting System



Powder Storage Unit



Plastic Pellet Producing Line



Liquid Storage Unit



Bulk Bag Feeding



PLC Control & Auto Weighting Touch Screen



Liquid Conveying Unit



Dust Collector



Turn Key-Pellet Auto Making System



Liquid Middle Tank



Weighting Screw Conveyor



Liquid Scale



Super Mixer & Kneader

PLASTIC PELLET / RUBBER SHEET PRODUCING LINE SOLUTION

KNEADER MACHINERY CO., LTD
YIHNA HITECHNIC CO., LTD

WEB: www.kneader.com.tw TEL: +886-6-2438586
MAIL: sales@kneader.com.tw FAX: +886-6-2434205
ADD: No.2, Lane 81, Niaosong 3rd St.,
Yongkang City, Tainan County 710, Taiwan



Extruder & Pellet Cooling System

Material Auto Weighting System

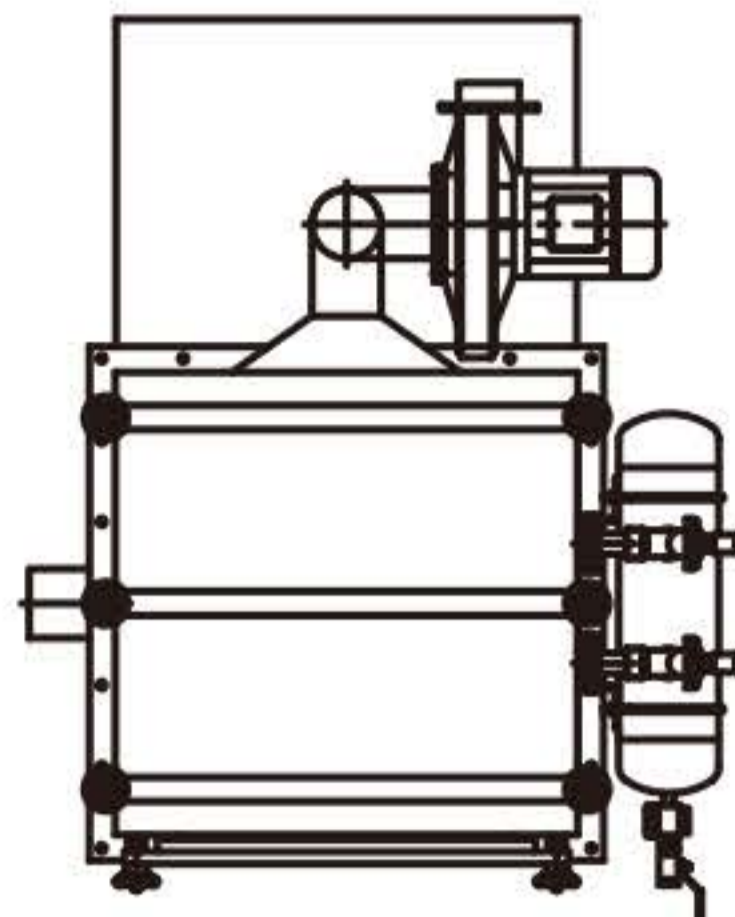

Dust Collector (Automatic Air Jet Cleaning)

Dust Collector is used for air conveying or powder unloading system for dust collecting.

Feature:

1. Easy to maintain and clean filter without tools.
2. Automatic air jet vibration drops dust.

Collection Efficiency:

1. Particle Size 1 ~ 2 μm : 85.7 %.
2. Particle Size 2 ~ 5 μm : 98.9 %.
3. Particle Size 5 ~ μm : 100 %.

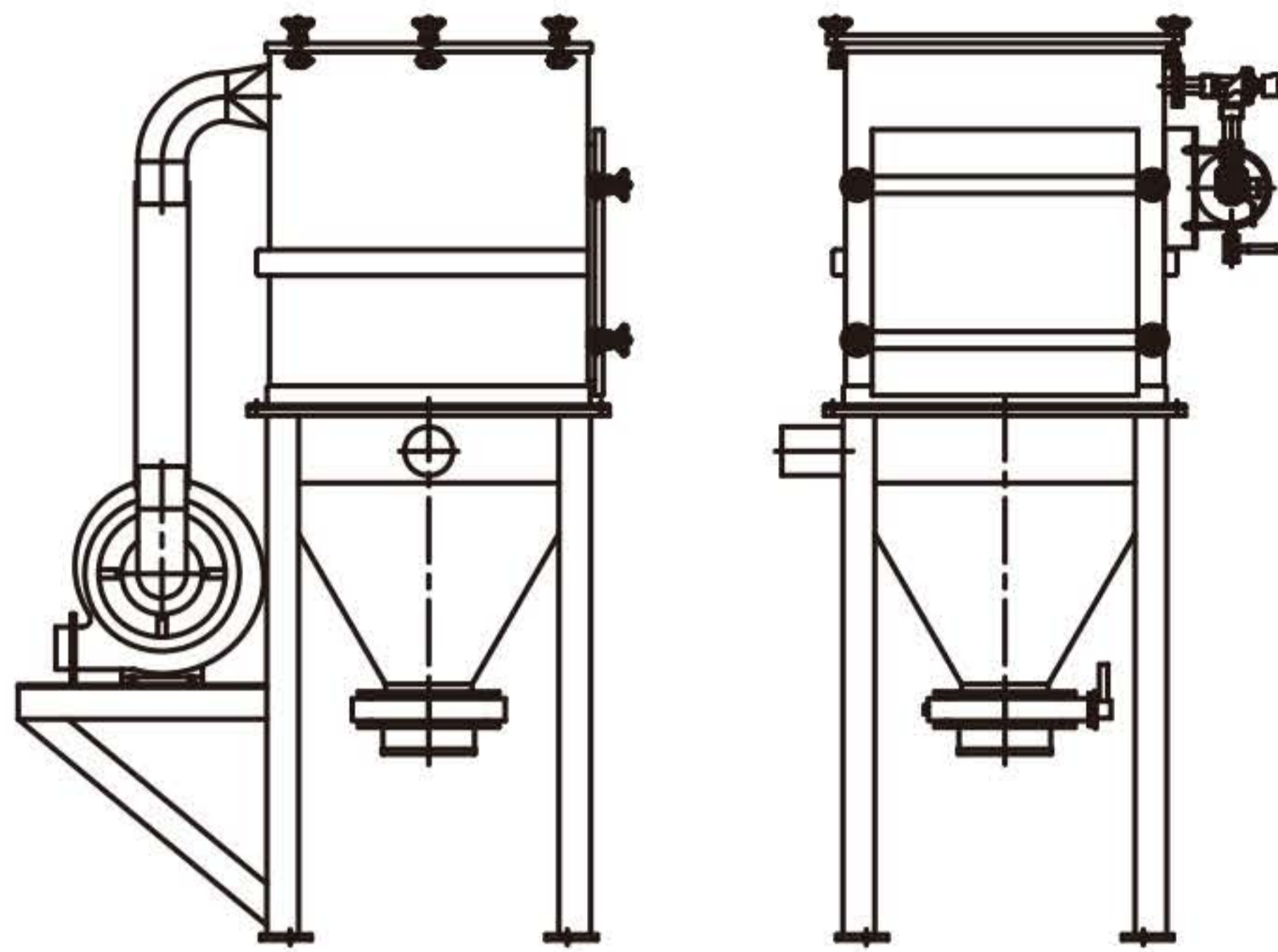

Powder Auto Weighting System

Powder Weighing Unit is designed to transport various powder materials into the weighing tank according the pre-set value (recipe).

The powders are transported by screw conveyor automatically. Every measured powder will store in the tank and wait for next discharge step.

Feature:

1. Automatic high efficient weighting and conveying.
2. High accurate weighting.

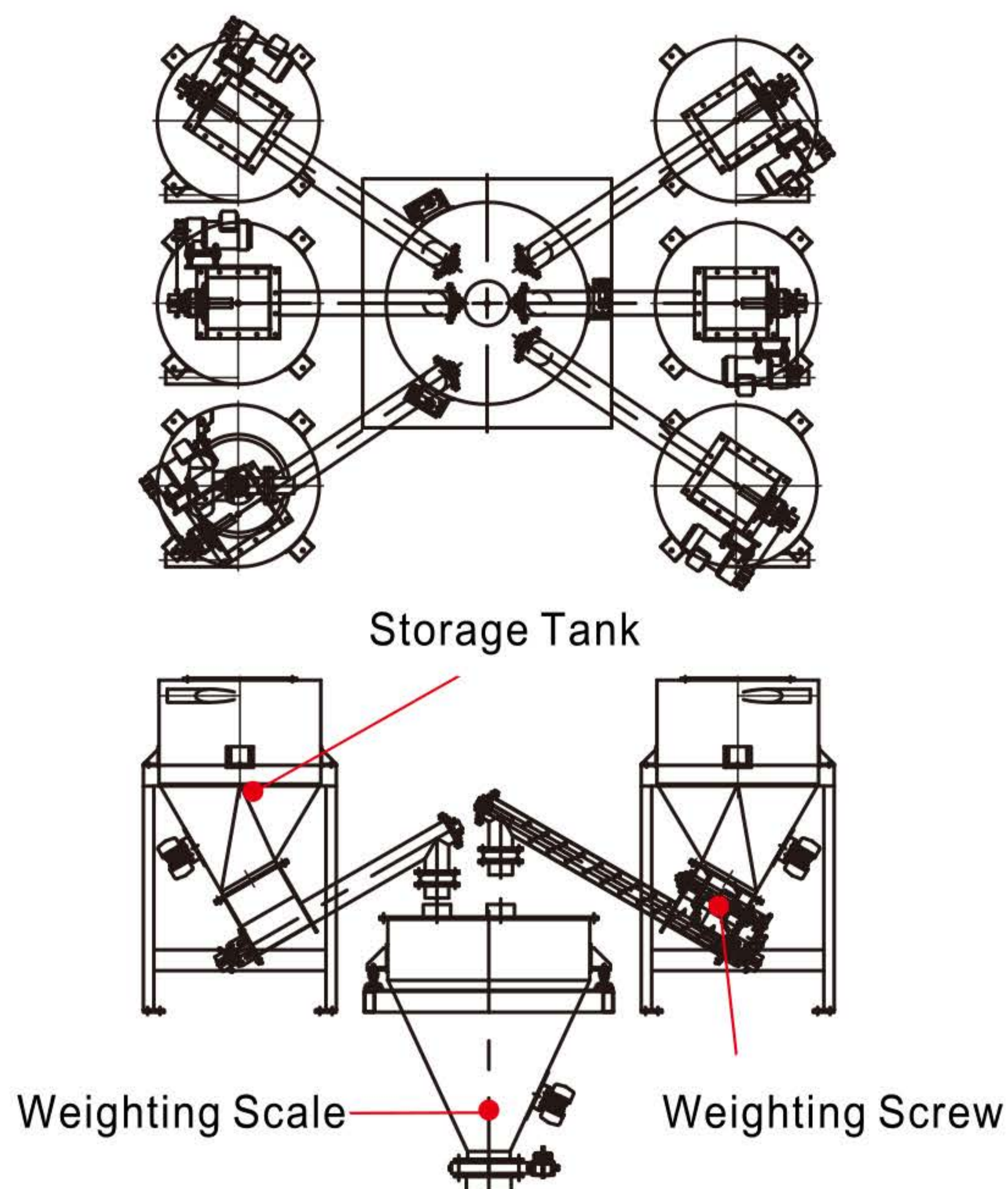

Liquid Auto Weighting System

Liquid Weighing Unit is designed to transport various liquid materials into the weighing tank according the pre-set value (recipe).

The liquid are transported by conveying pump automatically. Every batch of measured liquid will store in the tank and wait for next discharge step.

Feature:

1. Automatic high efficient weighting and conveying.
2. High accurate weighting.

