

KNEADER MACHINERY CO., LTD.

大用量自動計量設備 Large Quantity Auto Weight Scaling System

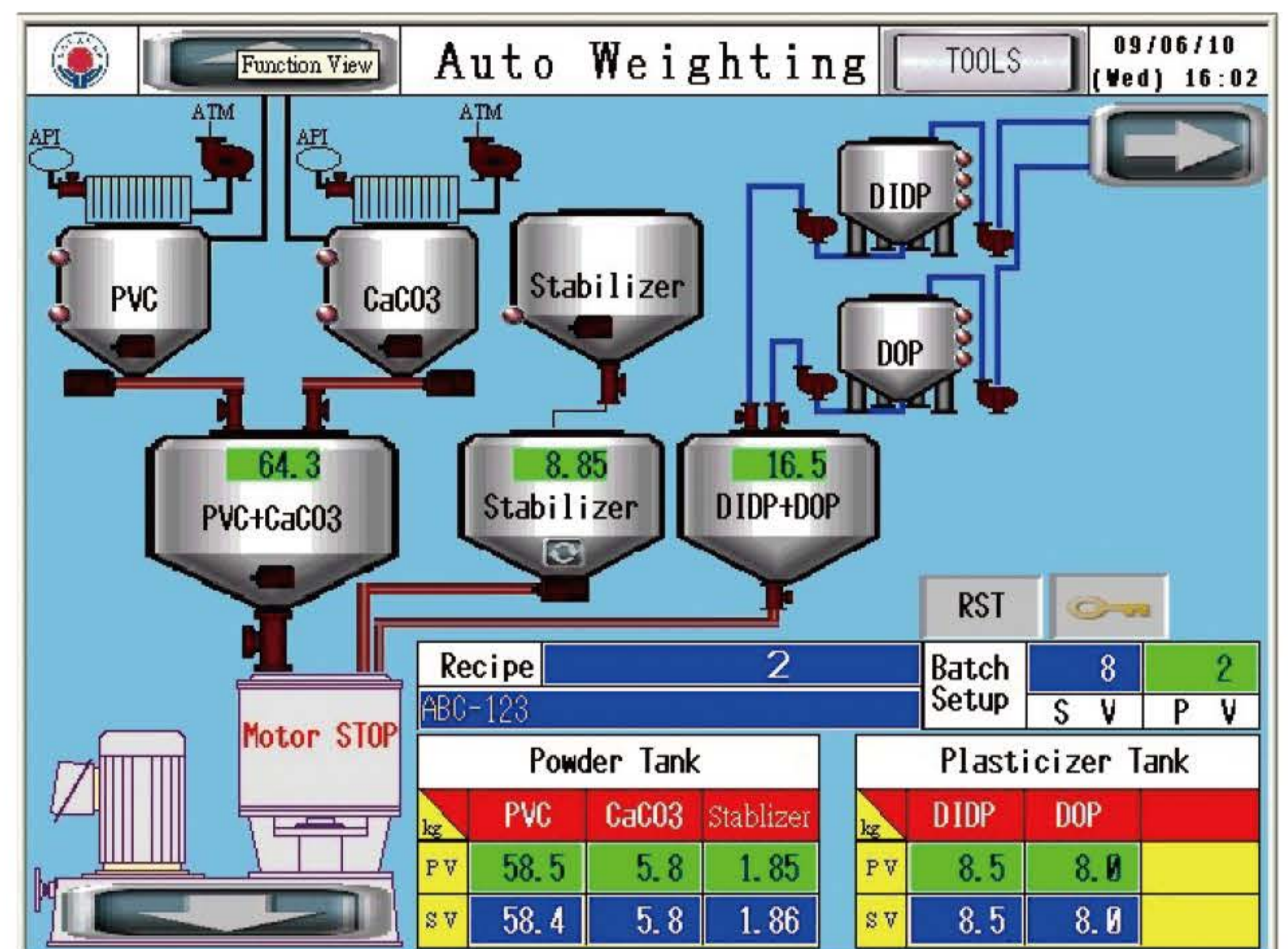
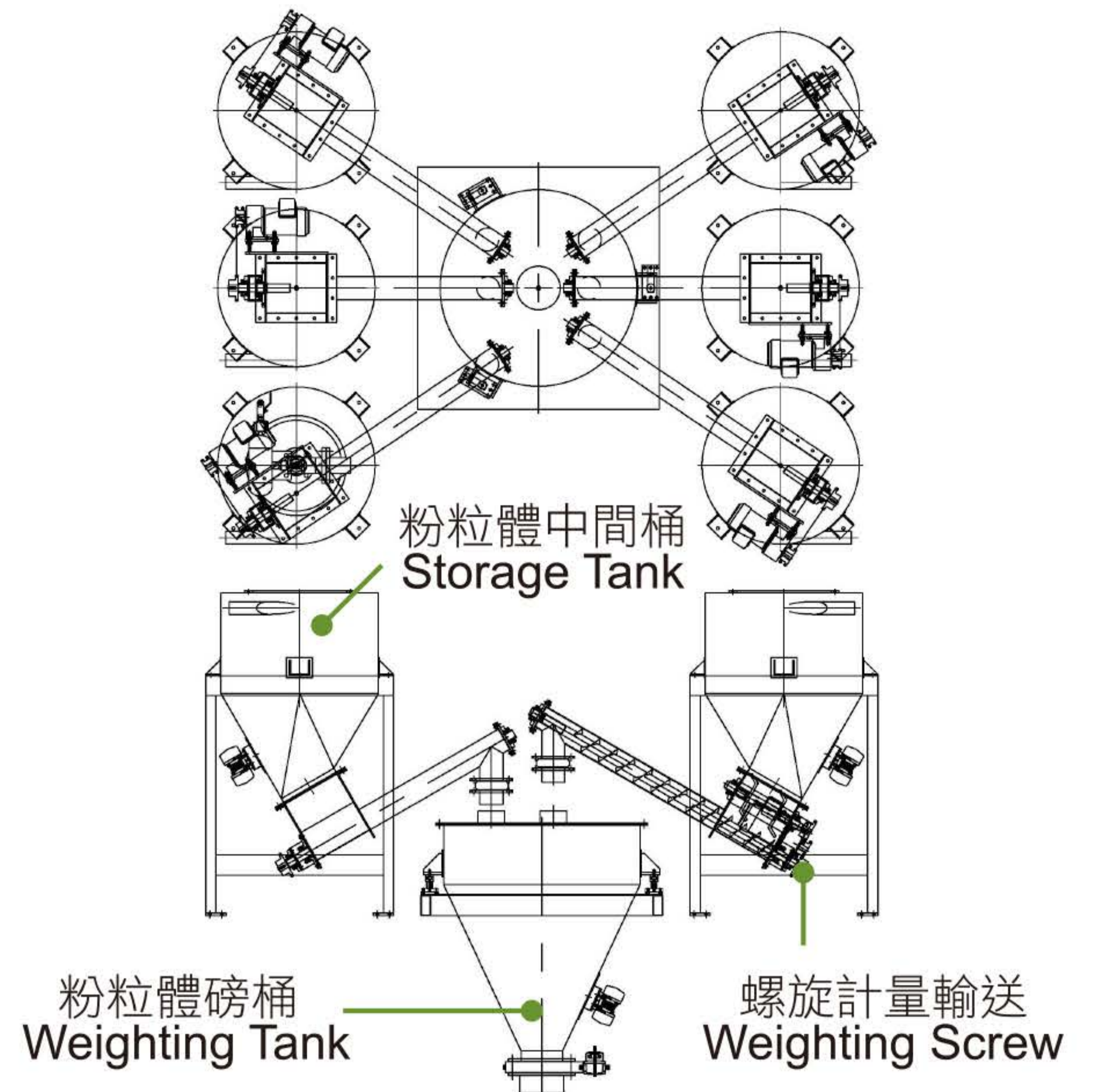

自動計量觸控式人機界面
Auto Weighting Control Panel

粉粒體計量設備，可依事先設定之配方原料倒入大用量料桶存放，經由風壓輸送至粉粒體中間桶，再依配方重量設定透過螺旋計量(可確保計量精準度)，自動將多種原料送至粉粒體磅桶磅秤，在完成批次計量後等待下料，再續作下批次計量處理。

特點：自動化高效率輸送計量，計量精準度高。

Powder Weighing Unit is designed to transport various powder materials into the weighing tank according the pre-set value (recipe). The powders are transported by screw conveyer automatically. Every measured powder will store in the tank and wait for next discharge step.

Feature: Automatic high efficient weighting and conveying. High accurate weighting.

利拿機械工業股份有限公司

台灣一廠：台南市永康工業區興工路3號 台灣二廠：台南市永康區蔦松三街81巷2號

Factory 1: No.3, Shing Gong Rd., Yong Kang Dist., Tainan City, Taiwan.

Factory 2: No.2, Ln. 81, Niaosong 3rd St., Yong Kang Dist., Tainan City, Taiwan

Tel: +886-6-2438586

Fax: +886-6-2434205

[HTTP://WWW.KNEADER.COM.TW](http://www.kneader.com.tw) E-MAIL: SALES@KNEADER.COM.TW